

www.dyctool.co.kr

2019/20

DYC TOOLS

Vol. 8



HSS-Co 8% 4F End Mills

하이스 4날
엔드밀
SKH59

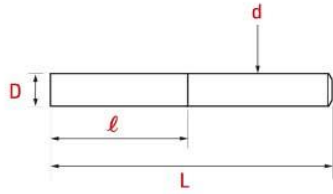

Item no. 제품코드	D 외경	ℓ 날장	L 전장	d 샤프크
EM01H9-010	1.0	2.5	55	6
EM01H9-015	1.5	4	55	6
EM01H9-020	2.0	6	55	6
EM01H9-025	2.5	7	55	6
EM01H9-030	3.0	10	55	6
EM01H9-035	3.5	12	60	6
EM01H9-040	4.0	12	60	6
EM01H9-045	4.5	15	65	6
EM01H9-050	5.0	15	65	6
EM01H9-055	5.5	15	65	6
EM01H9-060	6.0	15	65	6
EM01H9-065	6.5	20	75	8
EM01H9-070	7.0	20	75	8
EM01H9-075	7.5	20	75	8
EM01H9-080	8.0	20	75	8
EM01H9-085	8.5	25	80	10
EM01H9-090	9.0	25	80	10
EM01H9-095	9.5	25	80	10
EM01H9-100	10.0	26	80	10
EM01H9-105	10.5	30	90	12
EM01H9-110	11.0	30	90	12
EM01H9-115	11.5	30	90	12
EM01H9-120	12.0	31	90	12
EM01H9-125	12.5	35	95	12
EM01H9-130	13.0	35	95	12
EM01H9-140	14.0	35	100	16
EM01H9-150	15.0	40	105	16
EM01H9-160	16.0	40	105	16
EM01H9-170	17.0	40	105	16
EM01H9-180	18.0	40	105	16
EM01H9-190	19.0	45	115	20

Item no. 제품코드	D 외경	ℓ 날장	L 전장	d 샤프크
EM01H9-200	20.0	45	115	20
EM01H9-210	21.0	45	115	20
EM01H9-220	22.0	45	115	20
EM01H9-240	24.0	50	125	25
EM01H9-250	25.0	50	125	25
EM01H9-260	26.0	50	125	25
EM01H9-280	28.0	55	125	25
EM01H9-300	30.0	55	125	25
EM01H9-320	32.0	60	145	32
EM01H9-340	34.0	60	145	32
EM01H9-350	35.0	60	145	32
EM01H9-360	36.0	65	150	32
EM01H9-380	38.0	65	150	32
EM01H9-400	40.0	65	150	32
EM01H9-420	42.0	70	160	42
EM01H9-440	44.0	70	160	42
EM01H9-450	45.0	70	160	42
EM01H9-460	46.0	75	160	42
EM01H9-480	48.0	75	165	42
EM01H9-500	50.0	75	165	42

- Products except for the above standard items will be produced by the special order.
- 상기 목록 이외의 제품은 주문에 의해 제작됩니다.
- For the coating products item number, TiN or TiCN is added after the item no.
ex) Item no. - TiN or Item no. - TiCN
- 코팅 제품의 아이템 번호는 item no. 뒤에 TiN 또는 TiCN이 추가됩니다.
ex) Item no. - TiN or Item no. - TiCN

Tolerance (허용공차)		
D	d	L
≤ 20	0~+0.03	h6
≤ 50	0~+0.04	
		±1

HSS-Co 8% 4F Long End Mills

하이스 4날
롱 엔드밀
SKH59

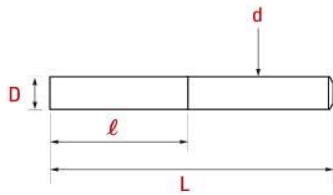

Item no. 제품코드	D 외경	ℓ 날장	L 전장	d 샤홅크
EM02H9-030	3.0	15	60	6
EM02H9-040	4.0	20	70	6
EM02H9-050	5.0	25	75	6
EM02H9-060	6.0	25	75	6
EM02H9-070	7.0	35	90	8
EM02H9-080	8.0	35	90	8
EM02H9-090	9.0	45	100	10
EM02H9-100	10.0	45	100	10
EM02H9-110	11.0	55	115	12
EM02H9-120	12.0	55	115	12
EM02H9-130	13.0	55	115	12
EM02H9-140	14.0	55	120	16
EM02H9-150	15.0	65	130	16
EM02H9-160	16.0	65	130	16
EM02H9-170	17.0	65	130	16
EM02H9-180	18.0	65	130	16
EM02H9-190	19.0	75	145	20
EM02H9-200	20.0	75	145	20

Tolerance (허용공차)		
D	d	L
≤ 20 0~+0.03	h6	±1
≧ 50 0~+0.04		

- Products except for the above standard items will be produced by the special order.
- 상기 목록 이외의 제품은 주문에 의해 제작됩니다.
- For the coating products item number, TiN or TiCN is added after the item no.
ex) Item no. - TiN or Item no. - TiCN
- 코팅 제품의 아이템 번호는 Item no. 뒤에 TiN 또는 TiCN이 추가됩니다.
ex) Item no. - TiN or Item no. - TiCN

HSS-Co 8% 2F End Mills

하이스 2날
엔드밀
SKH59

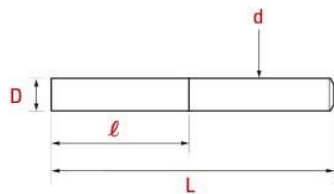

Item no. 제품코드	D 외경	ℓ 날장	L 전장	d 상크
EM03H9-010	1.0	2.5	55	6
EM03H9-015	1.5	4	55	6
EM03H9-020	2.0	6	55	6
EM03H9-025	2.5	7	55	6
EM03H9-030	3.0	10	55	6
EM03H9-035	3.5	12	60	6
EM03H9-040	4.0	12	60	6
EM03H9-045	4.5	15	65	6
EM03H9-050	5.0	15	65	6
EM03H9-055	5.5	15	65	6
EM03H9-060	6.0	15	65	6
EM03H9-065	6.5	20	75	8
EM03H9-070	7.0	20	75	8
EM03H9-075	7.5	20	75	8
EM03H9-080	8.0	20	75	8
EM03H9-085	8.5	25	80	10
EM03H9-090	9.0	25	80	10
EM03H9-095	9.5	25	80	10
EM03H9-100	10.0	26	80	10
EM03H9-105	10.5	30	90	12
EM03H9-110	11.0	30	90	12
EM03H9-115	11.5	30	90	12
EM03H9-120	12.0	31	90	12
EM03H9-125	12.5	35	95	12
EM03H9-130	13.0	35	95	12
EM03H9-140	14.0	35	100	16
EM03H9-150	15.0	40	105	16
EM03H9-160	16.0	40	105	16
EM03H9-170	17.0	40	105	16
EM03H9-180	18.0	40	105	16
EM03H9-190	19.0	45	115	20
EM03H9-200	20.0	45	115	20
EM03H9-210	21.0	45	115	20

Item no. 제품코드	D 외경	ℓ 날장	L 전장	d 상크
EM03H9-220	22.0	45	115	20
EM03H9-240	24.0	50	125	25
EM03H9-250	25.0	50	125	25
EM03H9-260	26.0	50	125	25
EM03H9-280	28.0	55	125	25
EM03H9-300	30.0	55	125	25
EM03H9-320	32.0	60	145	32
EM03H9-340	34.0	60	145	32
EM03H9-350	35.0	60	145	32
EM03H9-360	36.0	65	150	32
EM03H9-380	38.0	65	150	32
EM03H9-400	40.0	65	150	32
EM03H9-420	42.0	70	160	42
EM03H9-440	44.0	70	160	42
EM03H9-450	45.0	70	160	42
EM03H9-460	46.0	75	160	42
EM03H9-480	48.0	75	165	42
EM03H9-500	50.0	75	165	42

• Products except for the above standard items will be produced by the special order.
• 상기 목록 이외의 제품은 주문에 의해 제작됩니다.

• For the coating products item number, TiN or TiCN is added after the item no.
ex) Item no. - TiN or Item no. - TiCN

• 코팅 제품의 아이템 번호는 Item no. 뒤에 TiN 또는 TiCN이 추가됩니다.
ex) Item no. - TiN or Item no. - TiCN

Tolerance (허용공차)		
D	d	L
0~-0.03	h6	±1

HSS-PM 2F Ball End Mills

분말하이스
2날 볼 엔드밀
HSS-PM

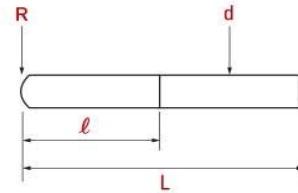

Item no. 제품코드	R 반경	ℓ 날장	L 전장	d 상크
EM10PM-005	R0.5	2.5	50	6
EM10PM-010	R 1.0	5	50	6
EM10PM-015	R 1.5	8	60	6
EM10PM-020	R 2.0	8	70	6
EM10PM-025	R 2.5	10	80	6
EM10PM-030	R 3.0	12	90	6
EM10PM-035	R 3.5	14	90	8
EM10PM-040	R 4.0	14	100	8
EM10PM-045	R 4.5	18	100	10
EM10PM-050	R 5.0	18	100	10
EM10PM-060	R 6.0	22	110	12
EM10PM-070	R 7.0	26	110	12
EM10PM-080	R 8.0	30	140	16
EM10PM-090	R 9.0	34	140	16
EM10PM-100	R 10.0	38	160	20

Tolerance (허용공차)		
D	d	L
0~-0.03	h6	±1

- Products except for the above standard items will be produced by the special order.
- 상기 목록 이외의 제품은 주문에 의해 제작됩니다.
- For the coating products item number, TiALN is added after the item no. ex) Item no. -TiALN
- 코팅 제품의 아이템 번호는 item no. 뒤에 TiALN이 추가됩니다. ex) item no. -TiALN

HSS-Co 8% 4F~6F Roughing End Mills

하이스 4날~6날
황삭용 엔드밀
SKH59

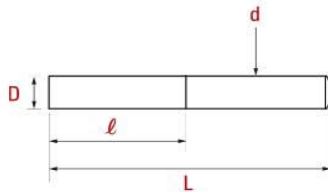

Item no. 제품코드	D 외경	ℓ 날장	L 전장	d 샤희크
EM06H9-060	6.0	15	60	6
EM06H9-070	7.0	20	65	8
EM06H9-080	8.0	20	65	8
EM06H9-090	9.0	25	75	10
EM06H9-100	10.0	25	75	10
EM06H9-110	11.0	30	80	12
EM06H9-120	12.0	30	80	12
EM06H9-130	13.0	35	90	12
EM06H9-140	14.0	35	90	12
EM06H9-150	15.0	40	95	12
EM06H9-160	16.0	40	95	16
EM06H9-170	17.0	40	95	16
EM06H9-180	18.0	40	105	16
EM06H9-190	19.0	45	110	16
EM06H9-200	20.0	45	110	20
EM06H9-210	21.0	45	110	20
EM06H9-220	22.0	45	110	20
EM06H9-230	23.0	45	110	20
EM06H9-240	24.0	50	120	25
EM06H9-250	25.0	50	120	25
EM06H9-260	26.0	50	120	25
EM06H9-270	27.0	55	125	25
EM06H9-280	28.0	55	125	25
EM06H9-300	30.0	55	125	25

Item no. 제품코드	D 외경	ℓ 날장	L 전장	d 샤희크
EM06H9-320	32.0	60	145	32
EM06H9-340	34.0	60	145	32
EM06H9-350	35.0	60	145	32
EM06H9-360	36.0	60	145	32
EM06H9-380	38.0	65	150	32
EM06H9-400	40.0	65	150	32
EM06H9-420	42.0	65	155	42
EM06H9-440	44.0	65	155	42
EM06H9-450	45.0	70	160	42
EM06H9-460	46.0	70	160	42
EM06H9-500	50.0	70	160	42

• Products except for the above standard items will be produced by the special order.

• 상기 목록 이외의 제품은 주문에 의해 제작됩니다.

• For the coating products item number, TiN or TiCN is added after the item no.
ex) Item no. - TiN or Item no. - TiCN

• 코팅 제품의 아이템 번호는 Item no. 뒤에 TiN 또는 TiCN이 추가됩니다.
ex) Item no. - TiN or Item no. - TiCN

Tolerance (허용공차)

D	d	L
±0.1	h6	±1

HSS-Co 8% 1F & 90° Countersinks

하이스 1날 & 90°
카운터싱크, SKH59

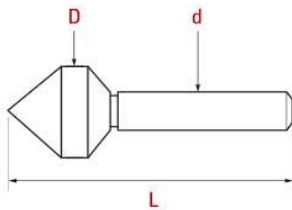

Item no. 제품코드	D 외경	L 전장	d 샤희경	Cutting Range 가공범위	α° 각도
CS01H9-010	10.0	50	6	2-9	90°
CS01H9-015	15.0	55	8	2-14	90°
CS01H9-020	20.0	60	10	2-19	90°
CS01H9-025	25.0	70	12	3-24	90°
CS01H9-030	30.0	75	12	6-29	90°
CS01H9-035	35.0	80	12	7-34	90°
CS01H9-040	40.0	85	12	8-39	90°
CS01H9-045	45.0	87	12	9-44	90°
CS01H9-050	50.0	90	12	12-49	90°

- Products except for the above standard items will be produced by the special order.
- 상기 목록 이외의 제품은 주문에 의해 제작됩니다.
- For the coating products item number, TiN or TiCN is added after the item no.
ex) Item no. - TiN or Item no. - TiCN
- 코팅 제품의 아이템 번호는 Item no. 뒤에 TiN 또는 TiCN이 추가됩니다.
ex) Item no. - TiN 또는 Item no. - TiCN

Tolerance (허용공차)			
D	Angle	d	L
±1	±1	h9	±1

HSS-Co 8% 3F Unequal Division & Unequal Lead Countersinks

하이스 3날 & 90°
부등분할 부등리드
카운터싱크, SKH59



Item no. 제품코드	D 외경	L 전장	d 상크경	d1 소경
CS08H9-063	6.3	45	5	1.5
CS08H9-083	8.3	50	6	2.0
CS08H9-104	10.4	50	6	2.5
CS08H9-125	12.4	56	8	2.8
CS08H9-165	16.5	60	10	3.2
CS08H9-205	20.5	63	10	3.5
CS08H9-250	25.0	68	10	3.8

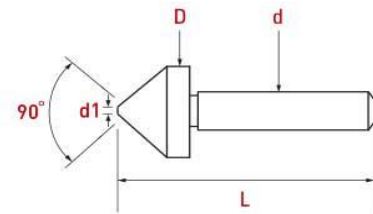

• Products except for the above standard items will be produced by the special order.
• 상기 목록 이외의 제품은 주문에 의해 제작됩니다.

- 1) 부등 분할(Unequal Division) & 부등 리드(Unequal Lead)
- 2) 릴리프 연마(Relief grinding) 커팅날(Cutting edges)
- 3) 높은 표면 경도(High surface hardness)와 내열온도(Anti-thermal)를 갖는 Alcrona Coating 적용
- 4) 다양한 재종의 공작물(Universal used materials)에 적용 가능한 M42(HSS-Co 8%) 소재 사용
- 5) 탁월한 가공면(Improved cutting surface)
- 6) 공구 수명 연장(Long tool life)
- 7) 안정적(Stable)이고 낮은 진동(Low Chattering)의 절삭 가공(Cutting)
- 8) 축 방향(Axial) 부하(Forces) 40% 감소(down)
- 9) 방사(Radial) 방향 부하(Forces) 30% 감소(down)
- 10) 고이속(Fast feed) 및 절삭 부하 감소(Reduced cutting forces)로 생산성 향상(High productivity)

Tolerance (허용공차)

D	Angle	d	L
±0.5	±0.5°	h8	±1

HSS-PM Power Long Drill

분말 하이스
파워 롱 드릴, HSS-PM

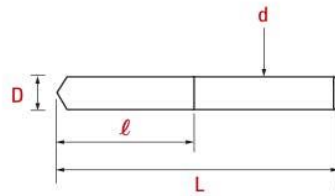

Item no. 제품코드	L 전장	
	100L	
	D 외경	ℓ 날장
DR03PM-10020	2.0	75
DR03PM-10025	2.5	75
DR03PM-10030	3.0	75
DR03PM-10035	3.5	75
DR03PM-10040	4.0	75
DR03PM-10045	4.5	75
DR03PM-10050	5.0	75
DR03PM-10055	5.5	75

Item no. 제품코드	L 전장	
	150L	
	D 외경	ℓ 날장
DR03PM-15020	2.0	100
DR03PM-15025	2.5	100
DR03PM-15030	3.0	100
DR03PM-15035	3.5	100
DR03PM-15040	4.0	100
DR03PM-15045	4.5	100
DR03PM-15050	5.0	100
DR03PM-15055	5.5	100
DR03PM-15060	6.0	100
DR03PM-15065	6.5	100
DR03PM-15070	7.0	100
DR03PM-15075	7.5	100
DR03PM-15080	8.0	100
DR03PM-15085	8.5	100
DR03PM-15090	9.0	100

특기사항

- 넓은 플루트 가공으로 칩 배출이 원활함
- 일반강부터 합금강 및 SUS까지 다양한 피삭재에 사용 가능함

Tolerance (허용공차)		
D	d	L
h8	h7	±1

Item no. 제품코드	L 전장	
	200L	
	D 외경	ℓ 날장
DR03PM-20020	2.0	150
DR03PM-20025	2.5	150
DR03PM-20030	3.0	150
DR03PM-20035	3.5	150
DR03PM-20040	4.0	150
DR03PM-20045	4.5	150
DR03PM-20050	5.0	150
DR03PM-20055	5.5	150
DR03PM-20060	6.0	150
DR03PM-20065	6.5	150
DR03PM-20070	7.0	150

Item no. 제품코드	L 전장	
	200L	
	D 외경	ℓ 날장
DR03PM-20075	7.5	150
DR03PM-20080	8.0	150
DR03PM-20085	8.5	150
DR03PM-20090	9.0	150
DR03PM-20095	9.5	150
DR03PM-20100	10.0	150
DR03PM-20105	10.5	150
DR03PM-20110	11.0	150
DR03PM-20115	11.5	150
DR03PM-20120	12.0	150

Item no. 제품코드	L 전장	
	250L	
	D 외경	ℓ 날장
DR03PM-25040	4.0	200
DR03PM-25045	4.5	200
DR03PM-25050	5.0	200
DR03PM-25055	5.5	200
DR03PM-25060	6.0	200
DR03PM-25065	6.5	200
DR03PM-25070	7.0	200
DR03PM-25075	7.5	200
DR03PM-25080	8.0	200
DR03PM-25085	8.5	200
DR03PM-25090	9.0	200
DR03PM-25095	9.5	200
DR03PM-25100	10.0	200
DR03PM-25105	10.5	200
DR03PM-25110	11.0	200
DR03PM-25115	11.5	200
DR03PM-25120	12.0	200
DR03PM-25125	12.5	200

Item no. 제품코드	L 전장		
	300L		
	D 외경		ℓ 날장
DR03PM-30055	5.5	33,500	200
DR03PM-30060	6.0	34,500	200
DR03PM-30065	6.5	37,000	200
DR03PM-30070	7.0	39,500	200
DR03PM-30075	7.5	42,000	200
DR03PM-30080	8.0	45,000	200
DR03PM-30085	8.5	47,000	200
DR03PM-30090	9.0	49,000	200
DR03PM-30095	9.5	52,000	200
DR03PM-30100	10.0	56,000	200
DR03PM-30105	10.5	61,000	200
DR03PM-30110	11.0	66,000	200
DR03PM-30115	11.5	71,000	200
DR03PM-30120	12.0	76,000	200
DR03PM-30125	12.5	81,000	200
DR03PM-30130	13.0	90,000	200

• Products except for the above standard items will be produced by the special order.
 • 상기 목록 이외의 제품은 주문에 의해 제작됩니다.

HSS-Co 5% 90° NC Spotting Drills

하이스 90°
엔씨 드릴, SKH55

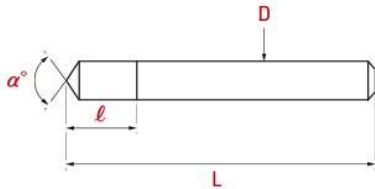

Item no. 제품코드	D 외경	l 날장	L 전장	α° 각도
NC01H5-90020	2.0	8	48	90°
NC01H5-90030	3.0	10	50	
NC01H5-90040	4.0	12	55	
NC01H5-90050	5.0	15	60	
NC01H5-90060	6.0	20	65	
NC01H5-90080	8.0	25	80	
NC01H5-90100	10.0	25	90	
NC01H5-90120	12.0	30	100	
NC01H5-90140	14.0	35	115	
NC01H5-90160	16.0	35	115	
NC01H5-90180	18.0	40	130	
NC01H5-90200	20.0	40	130	
NC01H5-90250	25.0	42	135	

Tolerance (허용공차)			
D	Angle(α)	L	l
h8	±1°	±1	±1

- Products except for the above standard items will be produced by the special order.
- 상기 목록 이외의 제품은 주문에 의해 제작됩니다.
- For the coating products item number, TiN or TiCN is added after the item no.
ex) Item no. - TiN or Item no. - TiCN
- 코팅 제품의 아이템 번호는 Item no. 뒤에 TiN 또는 TiCN이 추가됩니다.
ex) Item no. - TiN 또는 Item no. - TiCN

HSS-Co 8% Center Drills A Type (60°)

하이스 센터드릴
A형 (60°), SKH59

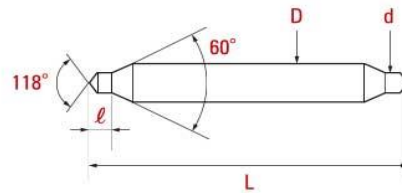

Item no. 제품코드	dXD 규격	L 전장	ℓ 축기장
CD01H9-0105	1.0X5.0	40	1.0-1.5
CD01H9-0156	1.5X6.0	40	2.0-2.5
CD01H9-0206	2.0X6.0	45	2.0-3.0
CD01H9-0256	2.5X6.0	50	2.5-3.5
CD01H9-0257	2.5X7.7	55	2.5-3.5
CD01H9-0307	3.0X7.7	55	3.0-4.0
CD01H9-0308	3.0X8.0	55	3.0-4.0
CD01H9-0408	4.0X8.0	55	4.5-5.5
CD01H9-0410	4.0X10.0	65	4.5-5.5
CD01H9-0510	5.0X10.0	65	5.5-6.5
CD01H9-0511	5.0X11.0	78	5.5-6.5
CD01H9-0612	6.0X12.0	78	6.5-7.5
CD01H9-0617	6.0X12.7	78	6.5-7.5
CD01H9-0816	8.0X16.0	90	8.0-9.0
CD01H9-1020	10.0X20.0	100	10.0-11.0

Tolerance (허용공차)		
D	d	L
h9	k12	±2

- Products except for the above standard items will be produced by the special order.
- 상기 목록 이외의 제품은 주문에 의해 제작됩니다.
- For the coating products item number, TiN or TiCN is added after the item no.
- ex) Item no. - TiN or Item no. - TiCN
- 코팅 제품의 아이템 번호는 Item no. 뒤에 TiN 또는 TiCN이 추가됩니다.
- ex) Item no. - TiN 또는 Item no. - TiCN

HSS 12° Helix Hand Reamers - Straight Shank

하이스 12° 헬릭스 핸드리머
직선샤홅크, SKH51

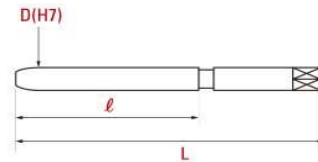

Item no. 제품코드	D 외경	ℓ 날장	L 전장
RM16H1-020	2.0	25	75
RM16H1-021	2.1	25	75
RM16H1-022	2.2	25	75
RM16H1-023	2.3	25	75
RM16H1-024	2.4	25	75
RM16H1-025	2.5	25	75
RM16H1-026	2.6	25	75
RM16H1-027	2.7	25	75
RM16H1-028	2.8	25	75
RM16H1-029	2.9	25	75
RM16H1-030	3.0	30	80
RM16H1-031	3.1	30	80
RM16H1-032	3.2	30	80
RM16H1-033	3.3	30	80
RM16H1-034	3.4	30	80
RM16H1-035	3.5	30	80
RM16H1-036	3.6	30	80
RM16H1-037	3.7	30	80
RM16H1-038	3.8	30	80
RM16H1-039	3.9	30	80
RM16H1-040	4.0	40	85
RM16H1-041	4.1	40	85

Item no. 제품코드	D 외경	ℓ 날장	L 전장
RM16H1-042	4.2	40	85
RM16H1-043	4.3	40	85
RM16H1-044	4.4	40	85
RM16H1-045	4.5	40	85
RM16H1-046	4.6	40	85
RM16H1-047	4.7	40	85
RM16H1-048	4.8	40	85
RM16H1-049	4.9	40	85
RM16H1-050	5.0	45	90
RM16H1-051	5.1	45	90
RM16H1-052	5.2	45	90
RM16H1-053	5.3	45	90
RM16H1-054	5.4	45	90
RM16H1-055	5.5	45	90
RM16H1-056	5.6	45	90
RM16H1-057	5.7	45	90
RM16H1-058	5.8	45	90
RM16H1-059	5.9	45	90
RM16H1-060	6.0	50	100
RM16H1-061	6.1	50	100
RM16H1-062	6.2	50	100
RM16H1-063	6.3	50	100

Item no. 제품코드	D 외경	ℓ 날장	L 전장
RM16H1-064	6.4	50	100
RM16H1-065	6.5	50	100
RM16H1-066	6.6	50	100
RM16H1-067	6.7	50	100
RM16H1-068	6.8	50	100
RM16H1-069	6.9	50	100
RM16H1-070	7.0	55	110
RM16H1-071	7.1	55	110
RM16H1-072	7.2	55	110
RM16H1-073	7.3	55	110
RM16H1-074	7.4	55	110
RM16H1-075	7.5	55	110
RM16H1-076	7.6	55	110
RM16H1-077	7.7	55	110
RM16H1-078	7.8	55	110
RM16H1-079	7.9	55	110
RM16H1-080	8.0	57	115
RM16H1-081	8.1	57	115
RM16H1-082	8.2	57	115
RM16H1-083	8.3	57	115
RM16H1-084	8.4	57	115
RM16H1-085	8.5	57	115
RM16H1-086	8.6	57	115
RM16H1-087	8.7	57	115
RM16H1-088	8.8	57	115
RM16H1-089	8.9	57	115
RM16H1-090	9.0	59	125
RM16H1-091	9.1	59	125
RM16H1-092	9.2	59	125
RM16H1-093	9.3	59	125
RM16H1-094	9.4	59	125
RM16H1-095	9.5	59	125
RM16H1-096	9.6	59	125
RM16H1-097	9.7	59	125
RM16H1-098	9.8	59	125
RM16H1-099	9.9	59	125
RM16H1-100	10.0	61	135
RM16H1-101	10.1	61	135
RM16H1-102	10.2	61	135
RM16H1-103	10.3	61	135
RM16H1-104	10.4	61	135
RM16H1-105	10.5	61	135
RM16H1-106	10.6	61	135

Item no. 제품코드	D 외경	ℓ 날장	L 전장
RM16H1-107	10.7	61	135
RM16H1-108	10.8	61	135
RM16H1-109	10.9	61	135
RM16H1-110	11.0	65	145
RM16H1-111	11.1	65	145
RM16H1-112	11.2	65	145
RM16H1-113	11.3	65	145
RM16H1-114	11.4	65	145
RM16H1-115	11.5	65	145
RM16H1-116	11.6	65	145
RM16H1-117	11.7	65	145
RM16H1-118	11.8	65	145
RM16H1-119	11.9	65	145
RM16H1-120	12.0	70	155
RM16H1-121	12.1	70	155
RM16H1-122	12.2	70	155
RM16H1-123	12.3	70	155
RM16H1-124	12.4	70	155
RM16H1-125	12.5	70	155
RM16H1-126	12.6	70	155
RM16H1-127	12.7	70	155
RM16H1-128	12.8	70	155
RM16H1-129	12.9	70	155
RM16H1-130	13.0	73	160
RM16H1-135	13.5	73	160
RM16H1-140	14.0	76	165
RM16H1-150	15.0	78	170
RM16H1-160	16.0	80	175
RM16H1-170	17.0	85	185
RM16H1-180	18.0	90	195
RM16H1-190	19.0	95	200
RM16H1-200	20.0	100	210
RM16H1-210	21.0	100	210
RM16H1-220	22.0	100	210

* Products except for the above standard items will be produced by the special order.
* 상기 목록 이외의 제품은 주문에 의해 제작됩니다.

Tolerance (허용공차)		
D	ℓ	L
m5	±1	±1

HSS Woodruff Keyseat Cutters T-Cutter

하이스 티 컷터, SKH51

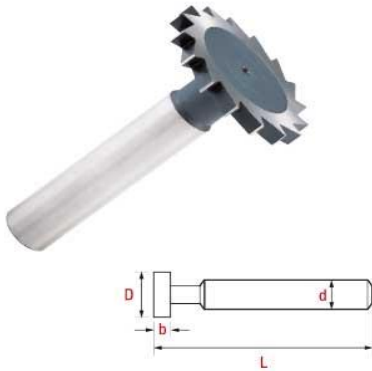
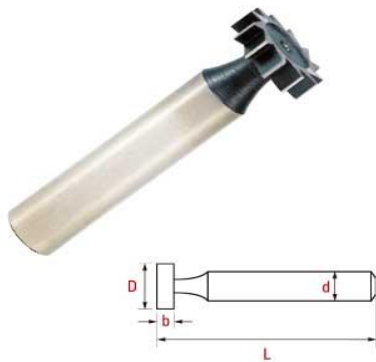

Tolerance (허용공차)		
b	d	L
e8	h8	±1

Item no. 제품코드	D 외경	No. of Flute 날수	d 상크	L 전장
TC01H1-010	10.0	8	10	50
TC01H1-012	12.0	8	12	52
TC01H1-013	13.0	8	12	55
TC01H1-014	14.0	8	12	55
TC01H1-015	15.0	8	12	58
TC01H1-016	16.0	10	12	58
TC01H1-018	18.0	10	12	60
TC01H1-019	19.0	10	12	60
TC01H1-020	20.0	10	12	60
TC01H1-022	22.0	10	12	60
TC01H1-024	24.0	12	12	60
TC01H1-025	25.0	12	12	62
TC01H1-026	26.0	12	12	62
TC01H1-028	28.0	12	12	65
TC01H1-030	30.0	12	12	65
TC01H1-032	32.0	14	12	65
TC01H1-035	35.0	14	12	67
TC01H1-038	38.0	14	12	70
TC01H1-040	40.0	14	12	72
TC01H1-045	45.0	14	16	76
TC01H1-050	50.0	16	16	85
TC01H1-060	60.0	18	16	95

- Products except for the above standard items will be produced by the special order.
- 상기 목록 이외의 제품은 주문에 의해 제작됩니다.
- The thickness sizes(b) of standard items are 1T, 2T, 2.5T, 3T, 4T, 5T, 6T, 7T, 8T, 9T, 10T and 12T.
- 표준품 두께 사이즈(b)는 1T, 2T, 2.5T, 3T, 4T, 5T, 6T, 7T, 8T, 9T, 10T, 12T 입니다.